

# YAKIMA

# FrontLoader

# US

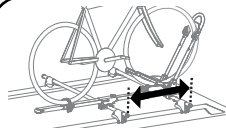

Crossbar Spread

16" - 18"  
41cm - 46cm

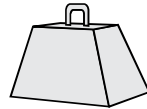

Weight Limit

30 lbs. (13.6kg)/bike  
2x max.  
**DO NOT EXCEED RACK WEIGHT LIMITS!**

18" - 48"  
46cm - 122cm

40 lbs. (18.1kg)/bike  
**DO NOT EXCEED RACK WEIGHT LIMITS!**

### \*CROSSBAR SPREAD

Your crossbar spread is the distance between the crossbars.

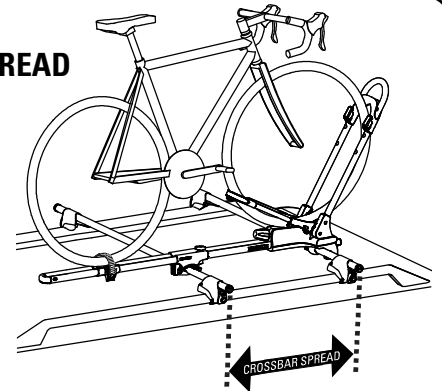

If you have factory crossbars, be sure you have at least 1-1/2" (3.8 cm) of clearance between the bottom of the crossbar and the vehicle roof.

FRONTLOADER (1X)

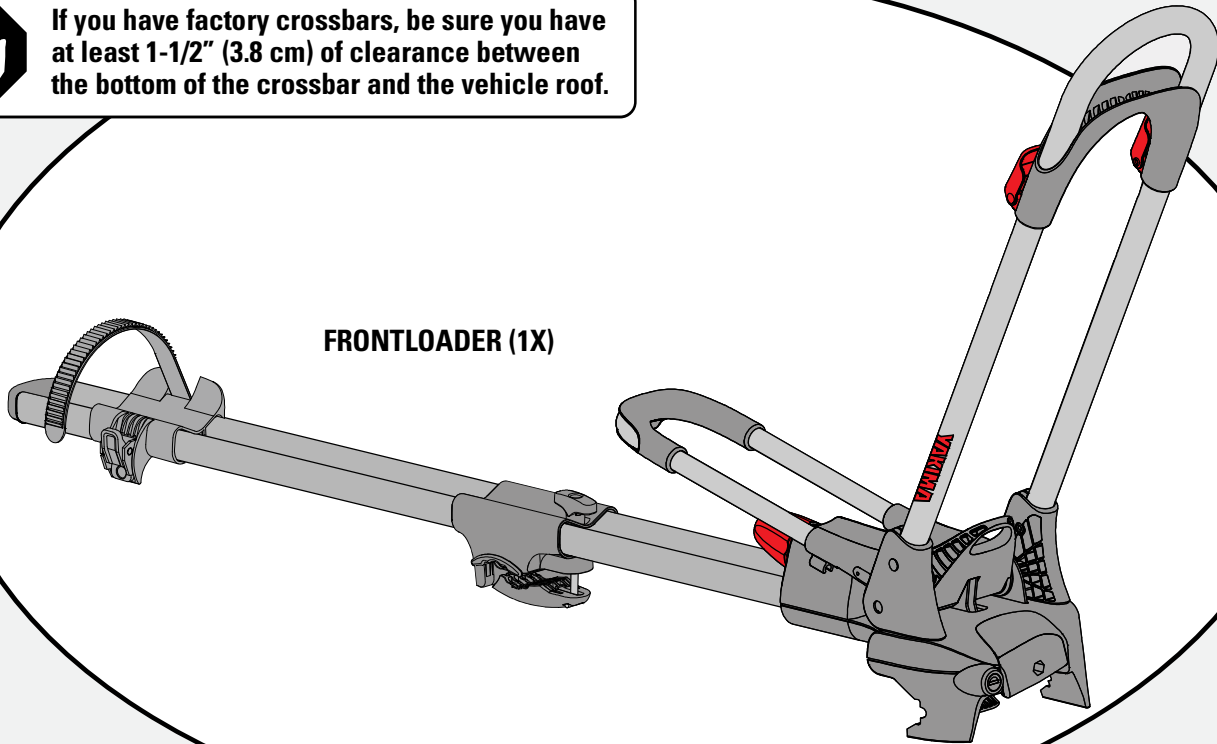

## IMPORTANT WARNING

IT IS CRITICAL THAT ALL YAKIMA RACKS AND ACCESSORIES BE PROPERLY AND SECURELY ATTACHED TO YOUR VEHICLE. IMPROPER ATTACHMENT COULD RESULT IN AN AUTOMOBILE ACCIDENT, AND COULD CAUSE SERIOUS BODILY INJURY OR DEATH TO YOU OR TO OTHERS. YOU ARE RESPONSIBLE FOR SECURING THE RACKS AND ACCESSORIES TO YOUR CAR, CHECKING THE ATTACHMENTS PRIOR TO USE, AND PERIODICALLY INSPECTING THE PRODUCTS FOR ADJUSTMENT, WEAR, AND DAMAGE. THEREFORE, YOU MUST READ AND UNDERSTAND ALL OF THE INSTRUCTIONS AND CAUTIONS SUPPLIED WITH YOUR YAKIMA PRODUCT PRIOR TO INSTALLATION OR USE. IF YOU DO NOT UNDERSTAND ALL OF THE INSTRUCTIONS AND CAUTIONS, OR IF YOU HAVE NO MECHANICAL EXPERIENCE AND ARE NOT THOROUGHLY FAMILIAR WITH THE INSTALLATION PROCEDURES, YOU SHOULD HAVE THE PRODUCT INSTALLED BY A PROFESSIONAL INSTALLER.

# 1 Place FrontLoader onto crossbars.

**Open the front clamp.** Turn the front knob counter clockwise to open the front the clamp.

**Open the rear clamp.** It may be necessary to turn the t-bolt to allow it to pass through the slot in the clamp.

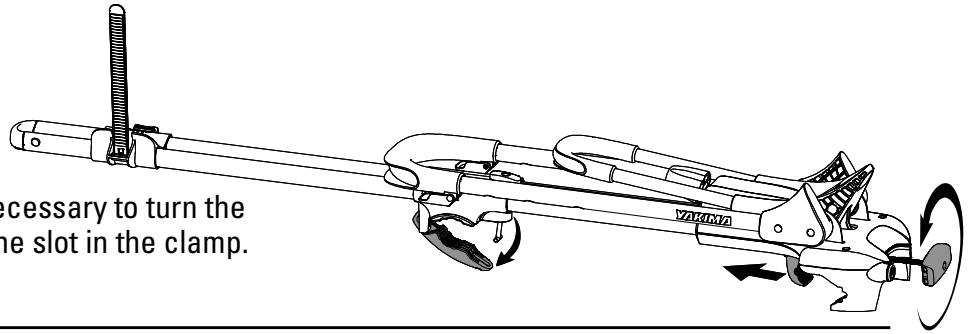

Lower the front clamp into place over front crossbar.

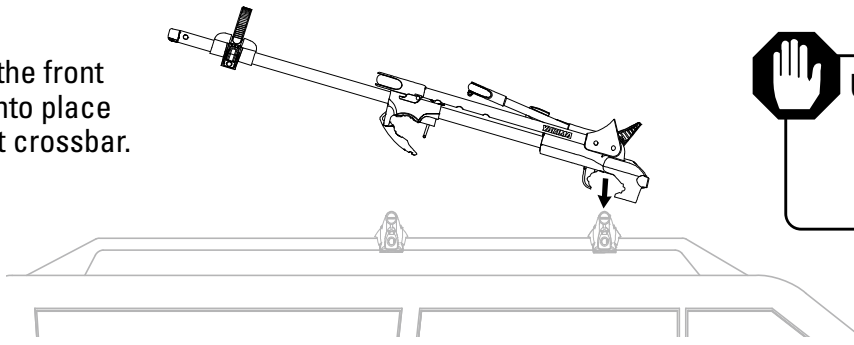

Use caution to avoid damaging roof's finish. A towel placed on the roof prior to installation can help avoid scratches.

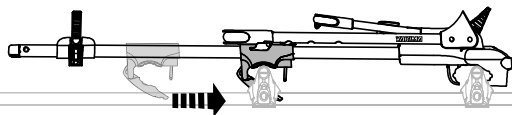

Slide the jaw of the rear clamp under rear crossbar.

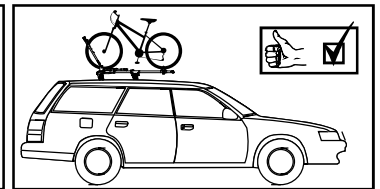
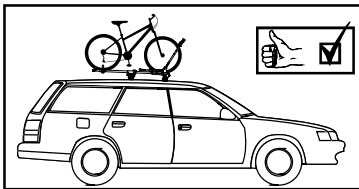
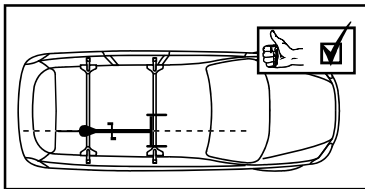
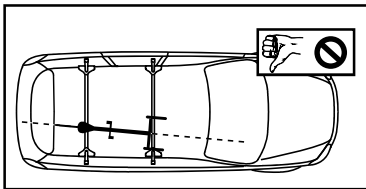
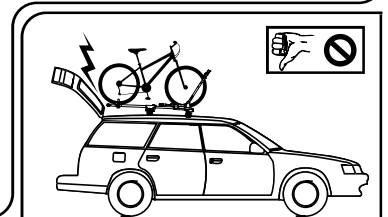

# 2 Tighten clamps.

**Tighten the front clamp.** Turn the knob clockwise to completely tighten the front clamp around crossbar.

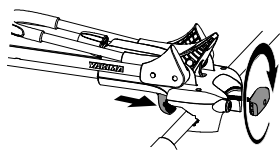

**Tighten the rear clamp.** Close rear clamp around rear crossbar.

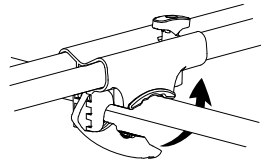

Pass the t-bolt through the opening in bail. Rotate t-bolt to rest in slot in bail.

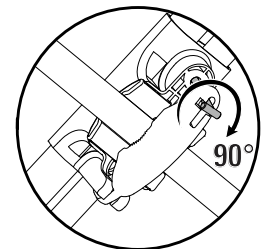
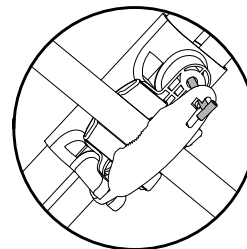

Turn the knob clockwise to completely tighten the rear clamp.

**Adjust clamp if necessary.**

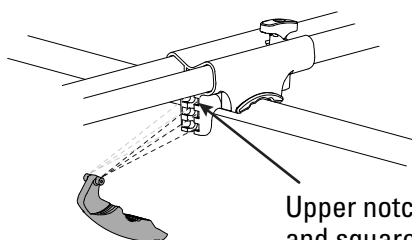

Upper notch for round and square bars.



If you don't get a secure grip with your factory bars adjust your clamp.

For factory bars choose the best position for most secure grip.

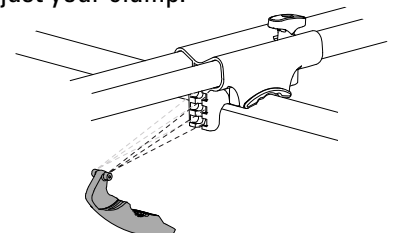



The rear clamp is configured for typical installations. In some situations adjustment may be necessary if the wheel makes contact with the rear knob, or if the wheeltray cannot reach the wheel.

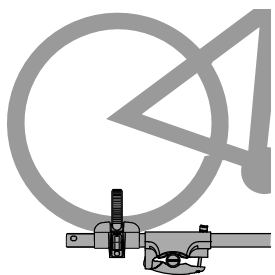

**OPTION A**  
Wheel behind  
rear crossbar.

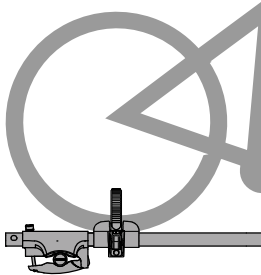

**OPTION B**  
Wheel ahead of  
rear crossbar.

If changing the orientation of the rear clamp still results in the rear wheel contacting the knob, please contact our customer service team (888-925-4621) for a free, corrective adapter.

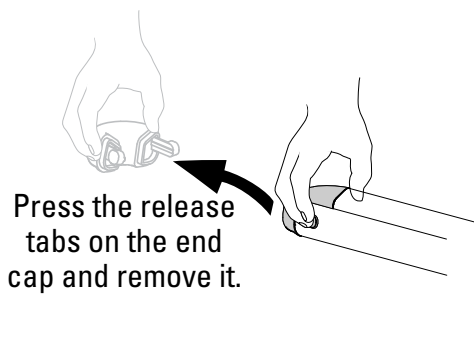
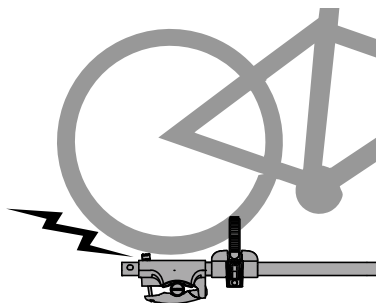

Press the release  
tabs on the end  
cap and remove it.

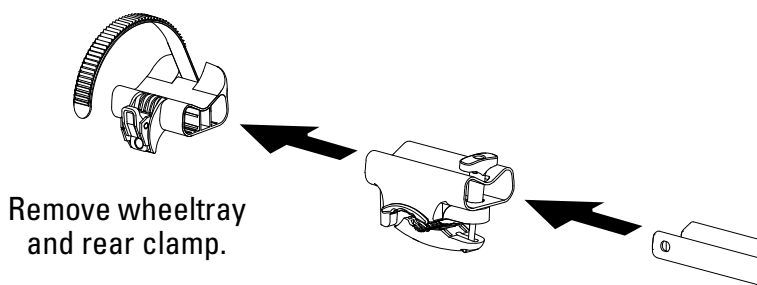

Remove wheeltray  
and rear clamp.

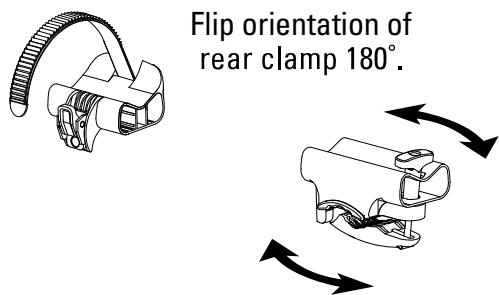

Flip orientation of  
rear clamp 180°.

**NOTE:** You can flip the wheeltray or rear clamp independently as needed. For instance if you needed the buckle on the opposite side you could flip the wheeltray as shown.

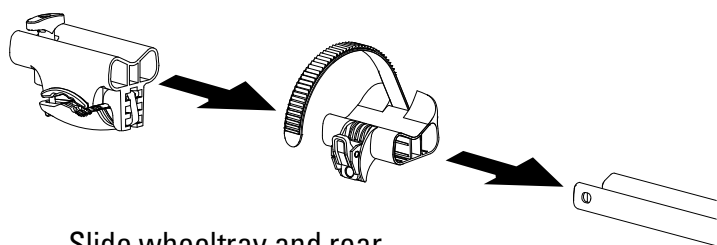
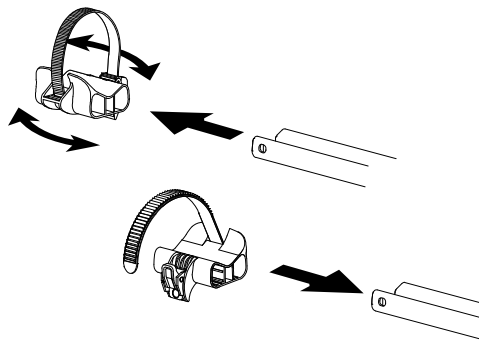

Slide wheeltray and rear  
clamp back onto forks.

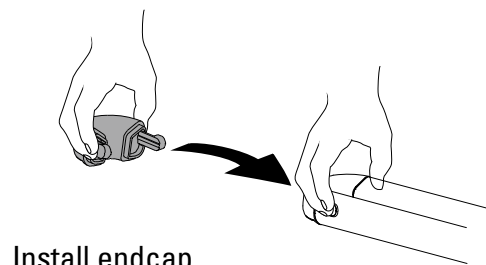

Install endcap.

### 3 Wheel Setting

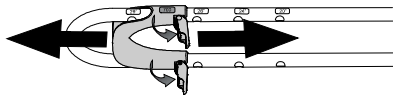

Look at your bike's tire to find your wheel size. Open the red levers on the wheel hoop to adjust wheel grip height.



Slide the wheel grip until the number matching your wheel size is visible through the window.

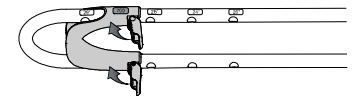
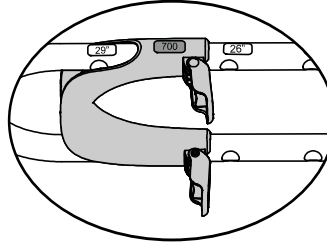

**CLOSE RED LEVERS.**

**IMPORTANT:** Make sure to check your bike tire sidewall for your tire size. The larger tire size settings have markings for both road and mountain bike tire size ranges. Always use the size range setting that corresponds with your tire size.

### 4 Load bike.



Open wheel hoop.

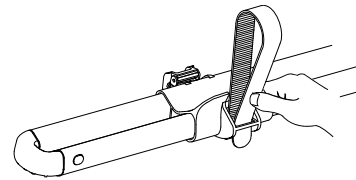

Tuck wheelstrap into the slot to make way for the tire.

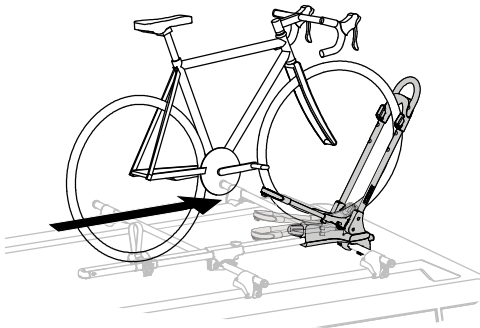

Lift your bike up and align front wheel with hoop while rolling forward. The small hoop will lever up.

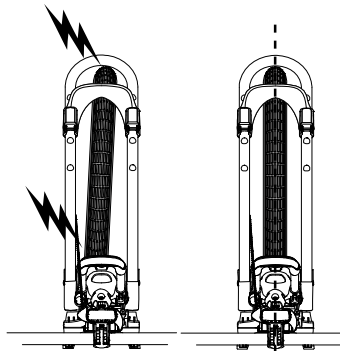

**! CENTER TIRE IN WHEELGRIP**

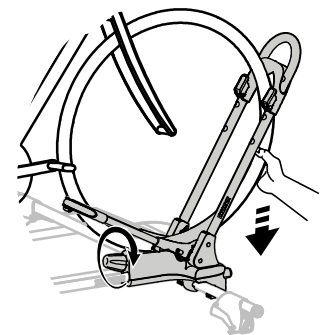

Pull down on wheel while turning the knob clockwise to tighten hoop.



**Do not use this product if your bike has fenders that prevent the hoops from direct contact with the tire.**

### 5 Secure rear wheel.

- Thread strap through spokes, and insert it into the slot in the wheeltray.
- Do not let strap push against valve stem.

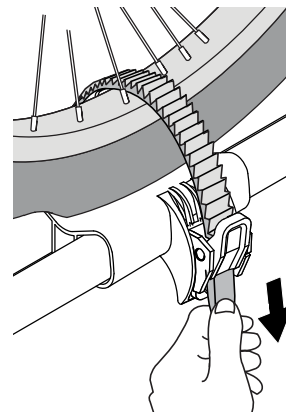
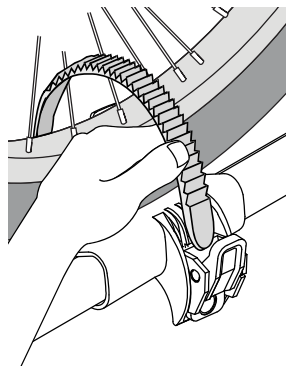

- Pull hard to tighten.

## 6 Lock your bike.



### INSTALL OPTIONAL LOCK CORES (sold separately).

If you have purchased locks, follow your lock core instructions to install. To purchase lock cores (Yakima Part Number 8007202) (2-pack) visit [www.yakima.com](http://www.yakima.com) or visit your local Yakima dealer.

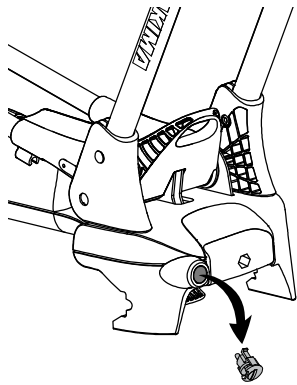

Follow the instructions that came with your lock cores to remove the lock plug and install your lock cores.

NOTE: Front knob must be in horizontal position to lock.

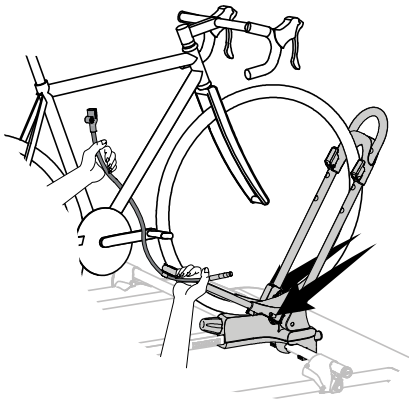
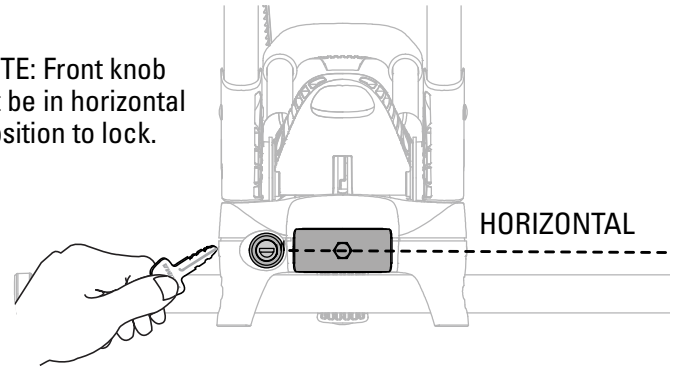

Follow the instructions that came with your lock cores to remove the lock plug and install your lock cores.

Access the built-in lock cable on either side of the small hoop. Store cable here when not in use.

Thread the cable through your bike frame, and insert silver post into lock housing.

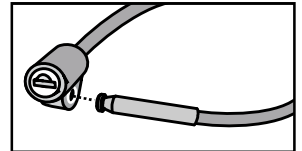

Turn the key counter-clockwise to lock.

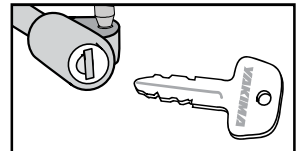

NOTE: For bikes with a slack head tube angle, long-travel suspension fork, and a large frame size/long wheelbase, the FrontLoader's lock cable may not reach all the way around the down tube of the frame. For the vast majority of bikes, this is NOT an issue. If your cable doesn't reach, then adjust the front wheel hoop to the 29" wheel.

## ✓ BEFORE DRIVING AWAY

### • CHECK REAR WHEEL.

Tighten the strap if needed.

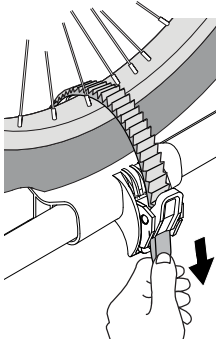

### • PERIODICALLY CHECK THAT KNOBS ARE ADEQUATELY TIGHTENED.

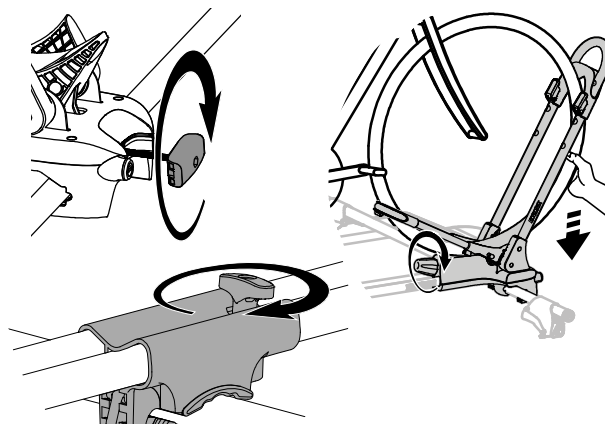

### • CHECK THAT FRONT WHEEL IS SECURE.

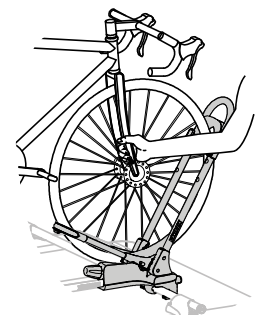

Continued on next page...

...before driving away.

**CHECK FRONT WHEEL ATTACHMENT TO BICYCLE FRAME.**

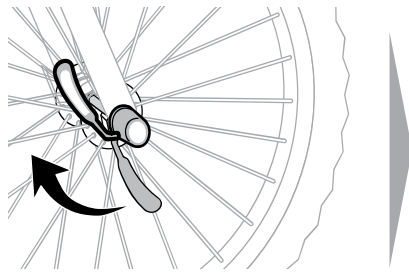

**MAKE SURE YOUR TIRES ARE FILLED TO RECOMMENDED PRESSURE FOUND ON THE TIRE.**

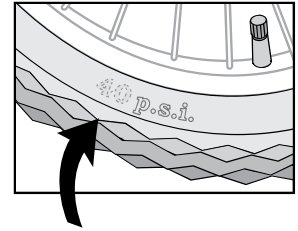

**Be sure to read all the warnings and warranty information contained in the insert accompanying these instructions!**



**IF YOU REMOVE CARRIER, FOLLOW INSTRUCTIONS TO REINSTALL.**

**Follow safety checks after every installation.**



**WARNING: BE SURE ALL HARDWARE IS SECURED ACCORDING TO INSTRUCTIONS. ATTACHMENT HARDWARE CAN LOOSEN OVER TIME. CHECK BEFORE EACH USE, AND TIGHTEN IF NECESSARY.**

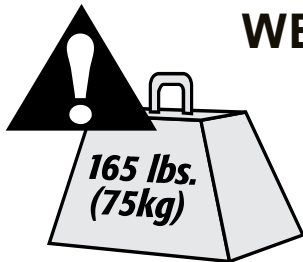

## WEIGHT LIMITS

**Follow the YAKIMA Fit List or check online at [Yakima.com](http://Yakima.com) for your rack's weight limit. Do not exceed the weight limit of your vehicle's rack.**

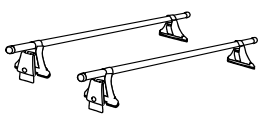

**RACK**

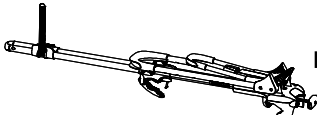

**THIS PRODUCT**  
(13 lbs. / 5.9 kg)



**LOAD**  
(40 lb / 18 kg maximum)



**Not more than 165 lbs. (75 kg) unless otherwise noted.**

**\*(Some vehicles will be rated lower than 165 lbs. (75 kg))**

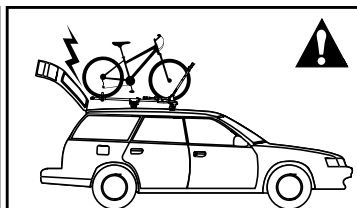
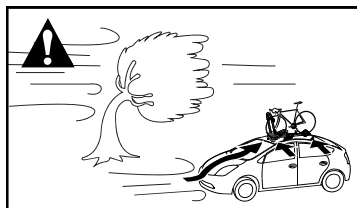
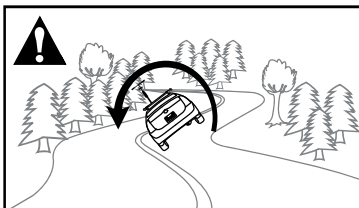
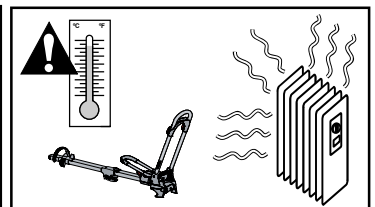
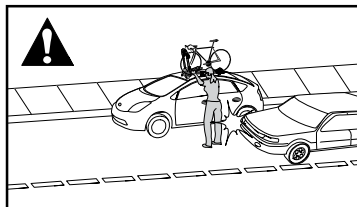
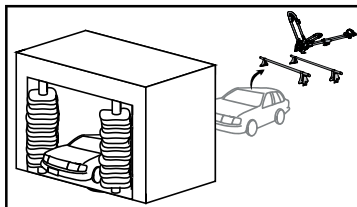
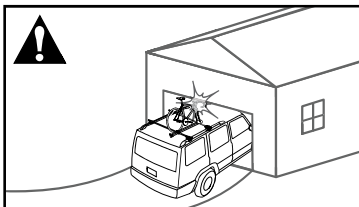

**KEEP THESE INSTRUCTIONS!**

# YAKIMA

# FrontLoader

# FR

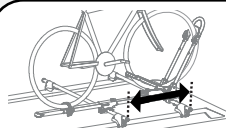

Distance entre les barres transversales\*

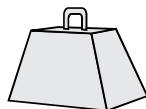

Limit

41cm - 46cm

13.6kg/vélo  
x2 max.

NE PAS DÉPASSER LA LIMITE DE CHARGE DU PORTE-BAGAGE !

46cm - 122cm

18.1kg/vélo  
NE PAS DÉPASSER LA LIMITE DE CHARGE DU PORTE-BAGAGE !

## \*DISTANCE ENTRE LES BARRES TRANSVERSALES

La distance entre les barres transversales c'est... la distance entre les barres transversales !

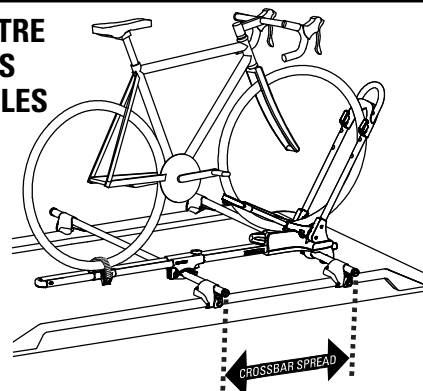

Si le montage se fait sur les barres transversales d'origine, vérifier que l'on dispose d'au moins 3,8 cm (1 ½ po) entre le dessous des barres et le toit.

FRONTLOADER (X1)

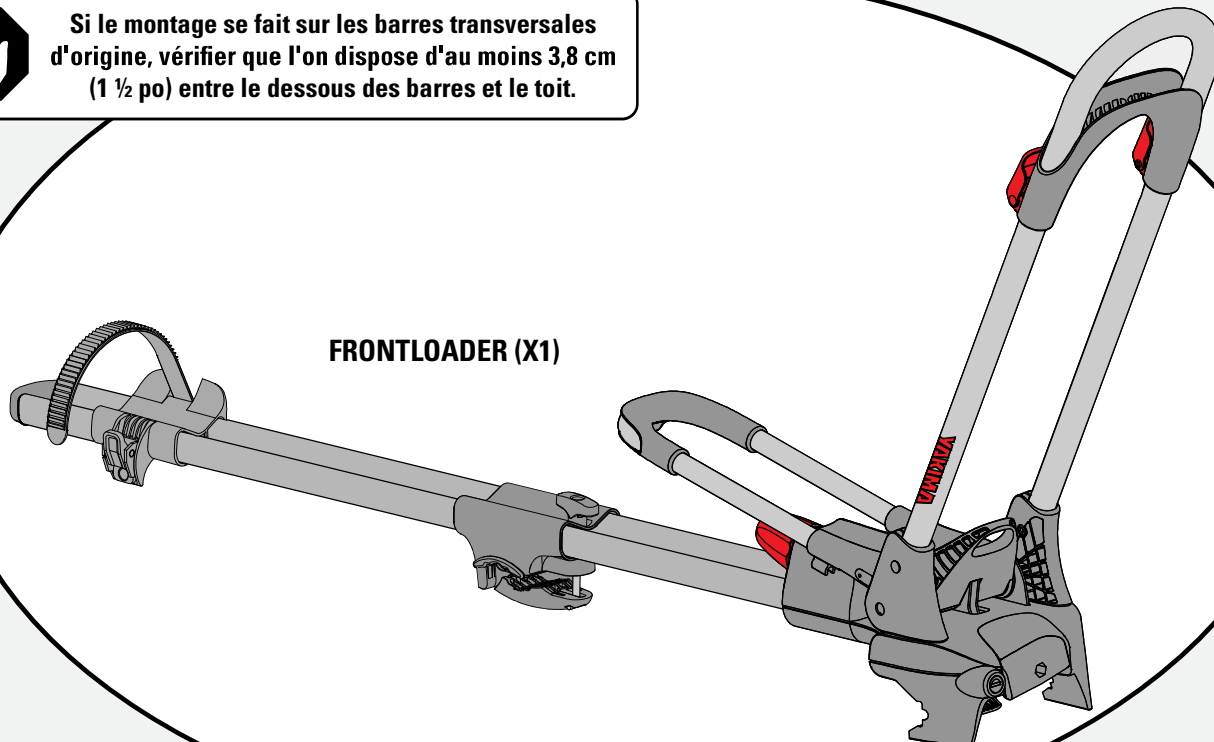

## AVERTISSEMENT IMPORTANT

IL EST IMPÉRATIF QUE LES PORTE-BAGAGES ET LES ACCESSOIRES YAKIMA SOIENT CORRECTEMENT ET SOLIDEMENT FIXÉS AU VÉHICULE. UN MONTAGE MAL RÉALISÉ POURRAIT PROVOQUER UN ACCIDENT D'AUTOMOBILE, QUI POURRAIT ENTRAÎNER DES BLESSURES GRAVES OU MÊME LA MORT, À VOUS OU À D'AUTRES PERSONNES. VOUS ÊTES RESPONSABLE DE L'INSTALLATION DU PORTE-BAGAGES ET DES ACCESSOIRES SUR VOTRE VÉHICULE, D'EN VÉRIFIER LA SOLIDITÉ AVANT DE PRENDRE LA ROUTE ET DE LES INSPECTER RÉGULIÈREMENT POUR EN CONTRÔLER L'ÉTAT, L'AJUSTEMENT ET L'USURE. VOUS DEVEZ DONC LIRE ATTENTIVEMENT TOUTES LES INSTRUCTIONS ET TOUS LES AVERTISSEMENTS ACCOMPAGNANT VOTRE PRODUIT YAKIMA AVANT DE L'INSTALLER ET DE L'UTILISER. SI VOUS NE COMPRENEZ PAS TOUTES LES INSTRUCTIONS ET TOUS LES AVERTISSEMENTS, OU SI VOUS N'AVEZ PAS DE COMPÉTENCES EN MÉCANIQUE ET NE COMPRENEZ PAS PARFAITEMENT LA MÉTHODE DE MONTAGE, VOUS DEVRIEZ FAIRE INSTALLER LE PRODUIT PAR UN PROFESSIONNEL, COMME UN MÉCANICIEN OU UN CARROSSIER COMPÉTENT.

# 1 Déposer le porte-vélo FrontLoader sur les barres transversales.

## Ouvrir la mâchoire avant.

Tourner le bouton avant vers la gauche pour ouvrir la mâchoire avant.

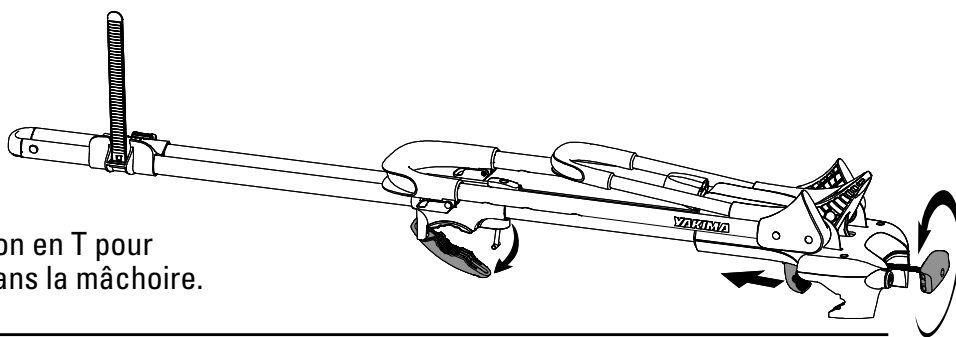

## Ouvrir la mâchoire arrière.

Il faudra peut-être tourner le boulon en T pour qu'il passe à travers l'ouverture dans la mâchoire.

Abaisser la mâchoire avant sur la barre avant.

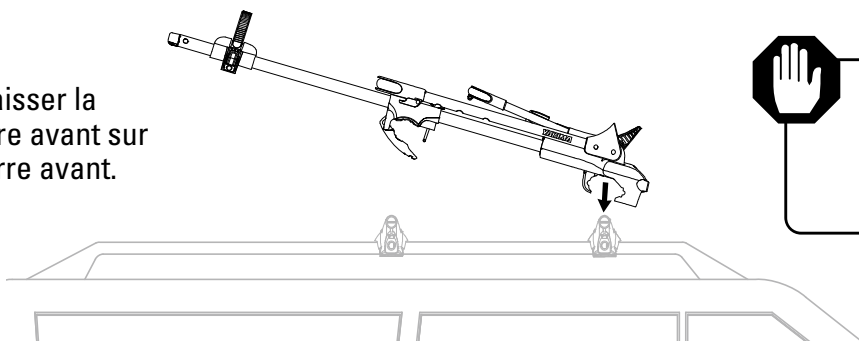

Faire attention de ne pas abîmer le fini du toit. Placer une serviette sur le toit pour éviter les égratignures.

Faire glisser la mâchoire arrière sous la barre arrière.

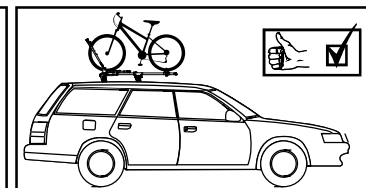
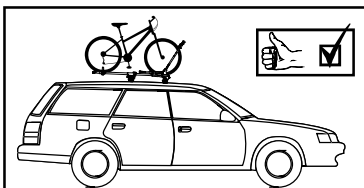
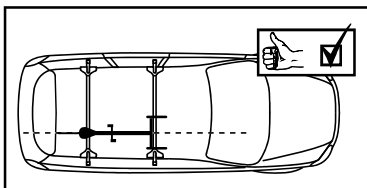
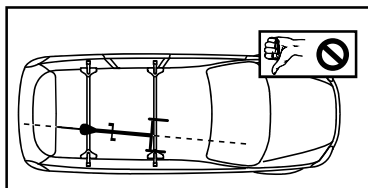
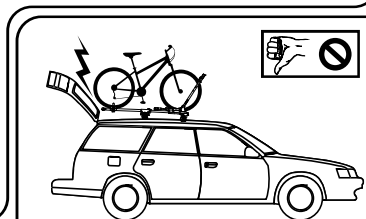
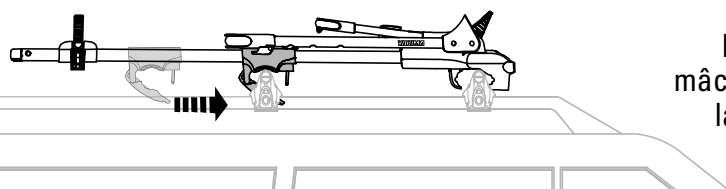

# 2 Serrer les mâchoires.

**Serre la mâchoire arrière.**  
Fermer la pince arrière sur la barre.

Enfiler le boulon en T dans l'ouverture de la mâchoire. Le tourner pour le caler dans la fente.

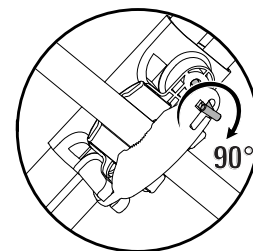
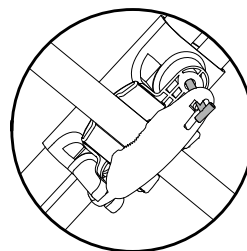
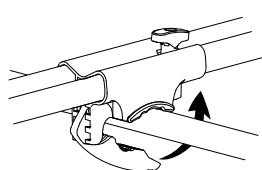
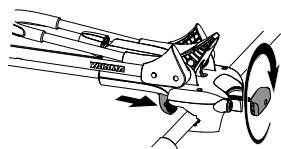

**Serrer la mâchoire avant.**  
Tourner le bouton vers la droite pour bien serrer la mâchoire contre la barre avant.

Tourner le bouton vers la droite pour bien serrer la mâchoire contre la barre arrière.

**Régler la position de la mâchoire si nécessaire.**



Si la mâchoire n'accroche pas bien sur la barre d'origine, régler la mâchoire.

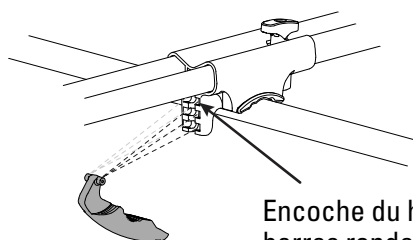

Encoche du haut pour les barres rondes et carrées.

Pour les barres d'origine, régler la mâchoire dans l'encoche qui offre la meilleure prise.

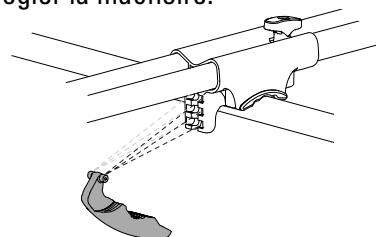





La pince arrière est placée pour le montage le plus courant. Dans certains cas, il faudra l'inverser si la roue entre en contact avec le bouton arrière ou si la roue ne rejoint pas la sangle.

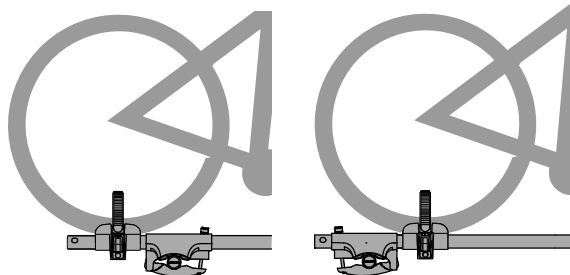

**OPTION A**

Roue derrière la barre arrière.

**OPTION B**

Roue devant la barre arrière.

Si la roue arrière touche tout de même au bouton même si on a inversé la pince arrière, prière de contacter notre service à la clientèle (au 888-925-4621) pour recevoir gratuitement un adaptateur spécial.

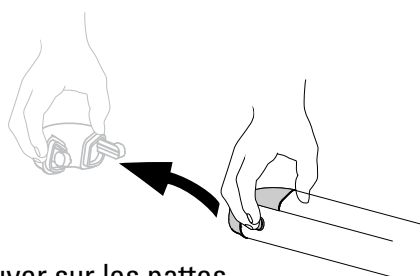
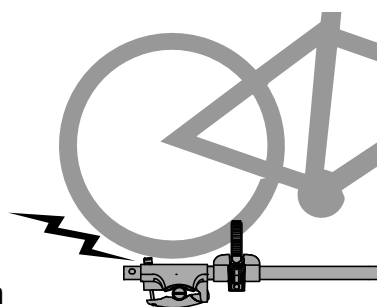

Appuyer sur les pattes et enlever la garniture d'extrémité du profilé.

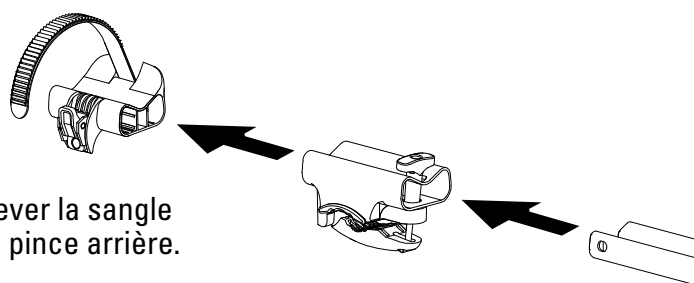

Enlever la sangle et la pince arrière.

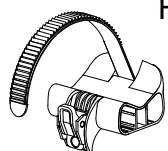

Retourner la pince arrière de 180°.

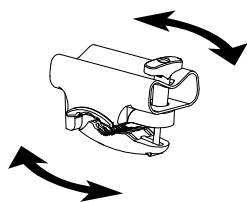

**REMARQUE :** on peut retourner la sangle ou la pince arrière séparément au besoin. Par exemple, si l'on veut la boucle de la sangle de l'autre côté, on peut la retourner tel qu'illustré.

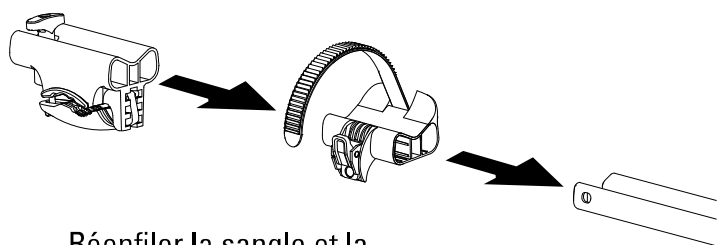
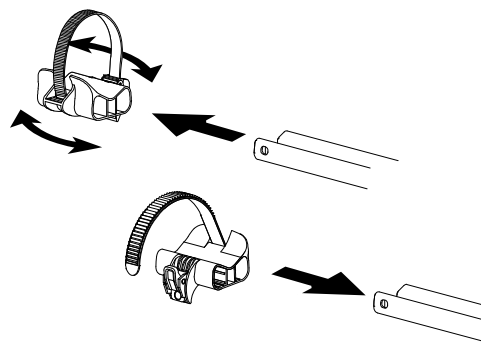

Réenfiler la sangle et la pince arrière sur le profilé.

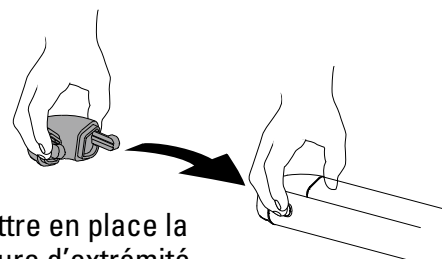

Remettre en place la garniture d'extrémité du profilé.

### 3 Régler l'arceau en fonction de la roue.

Faire coulisser la butée jusqu'à ce que le chiffre correspondant à la taille de la roue du vélo apparaisse dans la fenêtre.

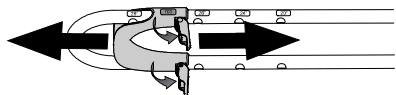

Regarder sur le pneu du vélo pour trouver la taille de la roue. Ouvrir les leviers rouges sur l'arceau pour régler la hauteur de la butée.

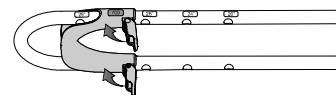
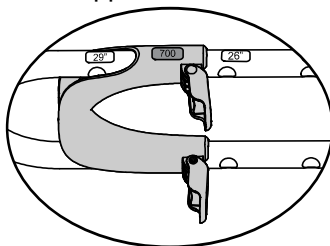

**FERMER LES LEVIERS ROUGES.**



Contrôlez la paroi du pneu de votre vélo pour déterminer sa taille. Les réglages de la taille du pneu le plus large sont équipés de marquages pour une gamme de pneu de vélo de route et de montagne. Utilisez toujours le réglage qui correspond le mieux à la taille de votre pneu.

### 4 Charger le vélo.

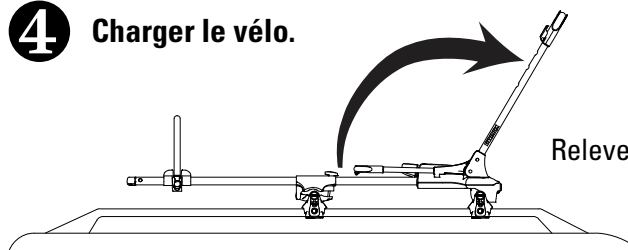

Relever l'arceau.

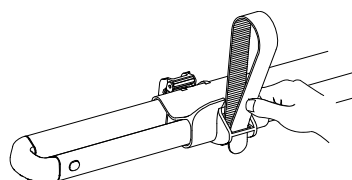

Caler la sangle dans la fente pour qu'elle ne gêne pas la roue.

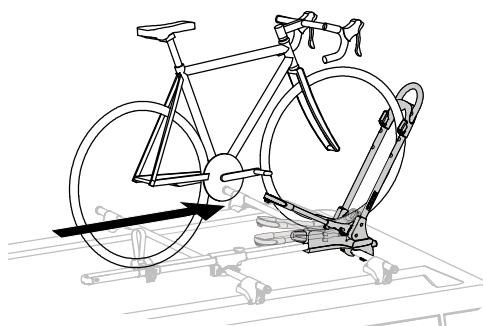

Soulever le vélo et aligner la roue avant dans l'arceau tout en faisant rouler le vélo vers l'avant. Le petit arceau basculera vers le haut.

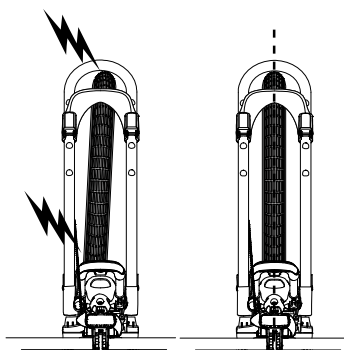

**CENTRER LE PNEU DANS LES ARCEAUX**

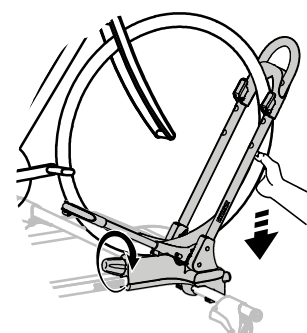

Tirer la roue vers le bas tout en tournant le bouton vers la droite pour serrer l'arceau.



**Ne pas employer ce produit si le vélo est muni d'une aile qui empêche l'arceau de faire contact directement avec le pneu.**

### 5 Immobiliser la roue arrière.

- Passer la sangle entre les rayons et l'insérer dans la fente sous le cliquet.
- Ne pas appuyer la sangle contre la tige de la valve.

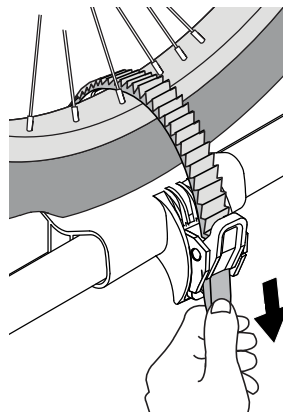
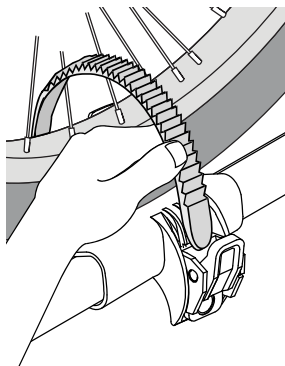

- Tirer fort pour serrer.

## 6 Verrouiller le vélo.

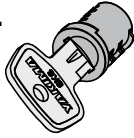

### POSER LES SERRURES OPTIONNELLES (vendues à part).

Si l'on a acheté des serrures, suivre les instructions qui les accompagnent pour les poser. Pour acheter des serrures (article Yakima n° 8007202 – emballage de deux) consulter le site [www.yakima.com](http://www.yakima.com) ou votre revendeur Yakima.

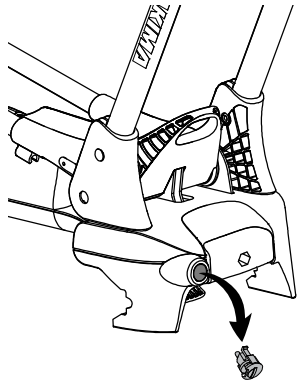

Suivre les instructions qui accompagnent les serrures pour enlever le bouchon et poser la serrure.

REMARQUE : le bouton avant doit être en position horizontale pour être verrouillé.

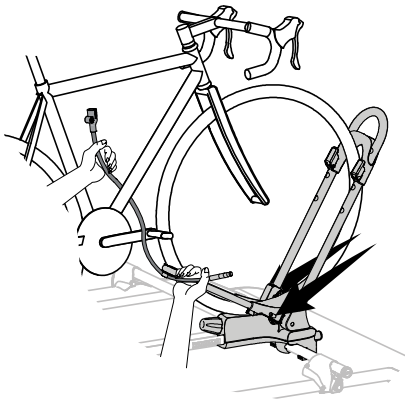
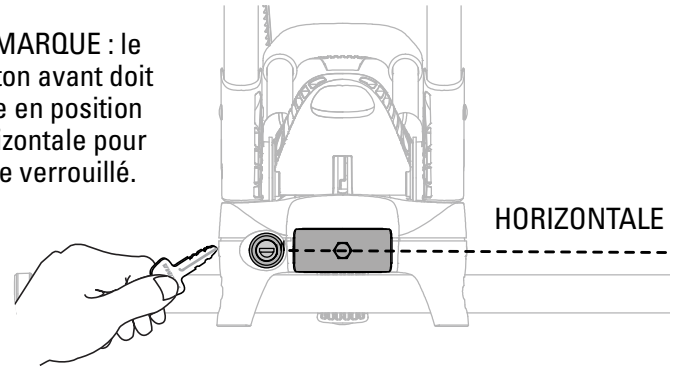

Suivre les instructions qui accompagnent les serrures pour enlever le bouchon et poser la serrure.

Passer le câble dans le cadre et engager l'ergot argenté dans la serrure.

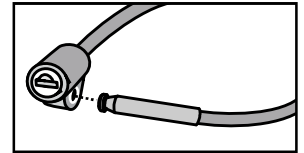

Sortir le câble de verrouillage incorporé de chaque côté du petit arceau. On peut y ranger le câble quand il ne sert pas.

Pour verrouiller, tourner la clé vers la gauche.

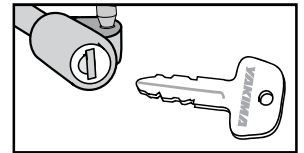

REMARQUE : Pour les vélos dont l'angle du tube de direction est faible, qui ont une fourche à grand débattement et un grand cadre et/ou un grand empattement, le câble de verrouillage ne fera peut-être pas complètement le tour du tube diagonal du cadre. Cela ne touche PAS la vaste majorité des vélos. Si le câble est trop court, régler l'arceau de la roue avant à 29 po.

## ✓ AVANT DE PRENDRE LA ROUTE

### • VÉRIFIER LA ROUE ARRIÈRE

Serrer la sangle au besoin.

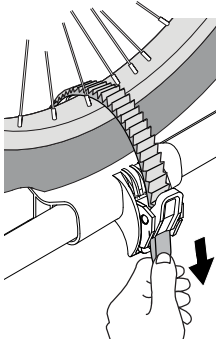

### • VÉRIFIER RÉGULIÈREMENT QUE LES BOUTONS SONT BIEN SERRÉS.

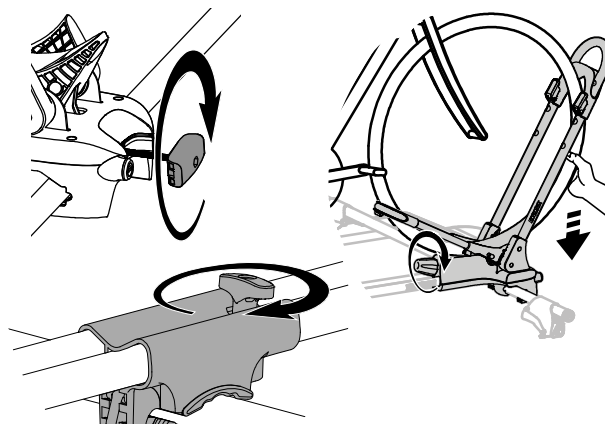

### • VÉRIFIER LA SOLIDITÉ DU MONTAGE DE LA ROUE AVANT.

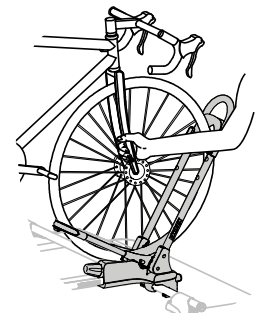

Suite page suivante...

... avant de prendre la route.

**VÉRIFIER QUE LA ROUE AVANT EST SOLIDEMENT FIXÉE À LA FOURCHE.**

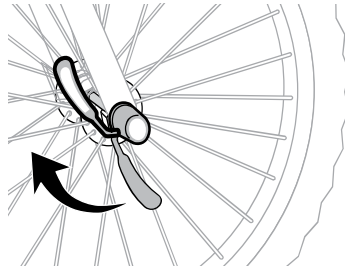

**S'ASSURER QUE LES PNEUS SONT GONFLÉS À LA PRESSION RECOMMANDÉE SUR LEUR FLANC.**

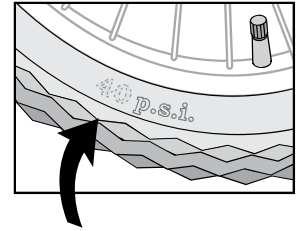

**S'assurer de lire les avertissements et les renseignements sur la garantie figurant sur le feuillet qui accompagne ces instructions !**



**SI L'ON ENLÈVE LE PORTE-VÉLO, SUIVRE LES INSTRUCTIONS POUR LE REMETTRE EN PLACE.**

**Effectuer les vérifications de sécurité après toute réinstallation.**



**AVERTISSEMENT: S'assurer que le montage est solide et conforme aux instructions. Les dispositifs de fixation peuvent se desserrer à la longue. Les inspecter avant chaque utilisation et les resserrer au besoin.**

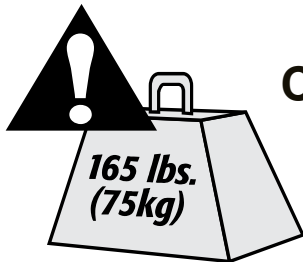

## LIMITE DE CHARGEMENT

Consulter la liste de compatibilité YAKIMA ("Fit list") ou le site Yakima.com pour connaître la limite de chargement du porte-bagages. Ne pas dépasser la limite de chargement fixée pour le porte-bagages d'origine.

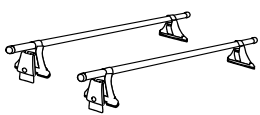

**PORTE-BAGAGES**

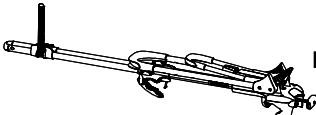

**CE PRODUIT**  
(5,9 kg / 13 lb)



**LA CHARGE**  
(18 kg / 40 lb maxi)



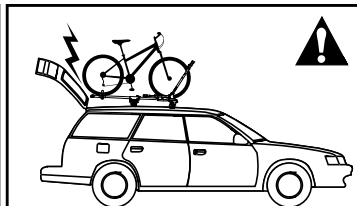
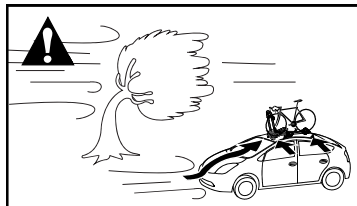
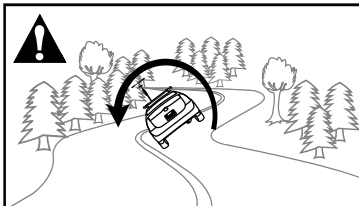
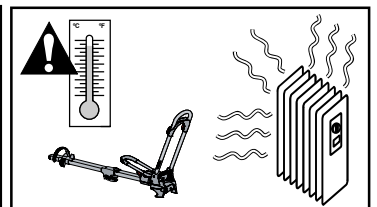
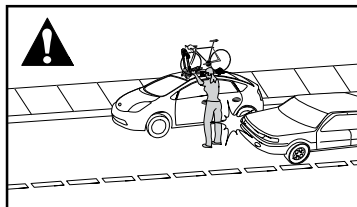
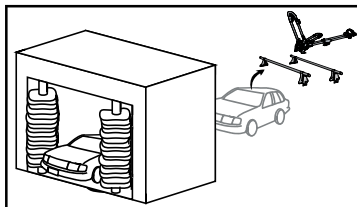
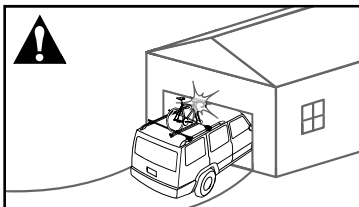

**Sur certains véhicules, la charge maximale est inférieure à 75 kg (165 lb)**

**\*(Some vehicles will be rated lower than 165 lbs. (75 kg))**

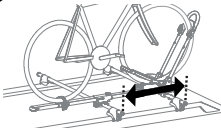
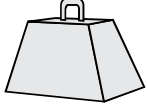

**CONSERVER CES INSTRUCTIONS !**

# YAKIMA FrontLoader **ES**

 <p>Separación entre travesaños*</p>	 <p>Límites</p>
<p>41cm - 46cm</p>	<p>13.6kg/vélo 2x  max. ¡NO EXCEDA LOS LÍMITES DE CARGA DEL PORTABICICLETA!</p>
<p>46cm - 122cm</p>	<p>18.1kg/vélo ¡NO EXCEDA LOS LÍMITES DE CARGA DEL PORTABICICLETA!</p>

## \*SEPARACIÓN ENTRE TRAVESAÑOS

La separación entre travesaños es la distancia entre las barras transversales.

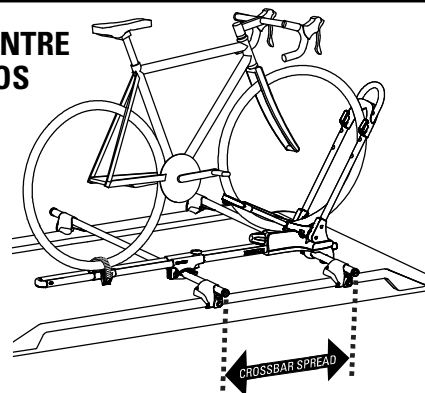

Si usted tiene barras transversales de origen, asegúrese de dejar una separación de por lo menos 1 1/2" (3,8 cm) entre la parte inferior de la barra y el techo del vehículo.

FRONTLOADER (1X)

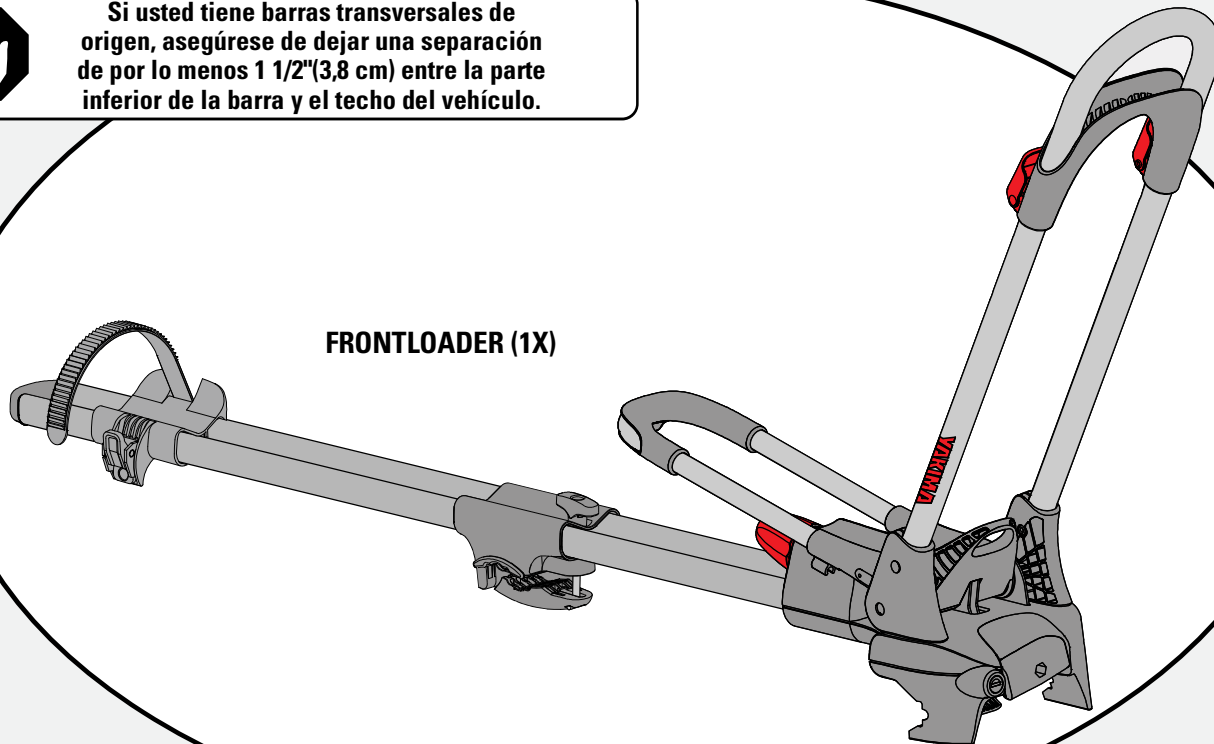

### AVISO IMPORTANTE:

ES FUNDAMENTAL QUE TODAS LAS PARRILLAS Y ACCESORIOS YAKIMA ESTÉN BIEN COLOCADOS Y ASEGURADOS AL VEHÍCULO. UNA INSTALACIÓN DEFICIENTE PODRÍA RESULTAR EN ACCIDENTE AUTOMOVILÍSTICO Y PROVOCAR HERIDAS GRAVES O MUERTE A USTED O A TERCEROS. USTED ES RESPONSABLE DE ASEGURAR LAS PARRILLAS Y ACCESORIOS AL VEHÍCULO, VERIFICANDO UNIONES Y AMARRES ANTES DE USAR E INSPECCIONANDO EL AJUSTE DE LOS PRODUCTOS, SU DESGASTE Y POSIBLES DAÑOS. POR ELLO DEBE LEER Y COMPRENDER TODAS LAS INSTRUCCIONES Y ADVERTENCIAS QUE VIENEN CON LOS PRODUCTOS YAKIMA ANTES DE INSTALARLOS O USARLOS. SI NO ENTIENDE TODAS LAS INSTRUCCIONES Y ADVERTENCIAS, O NO TIENE EXPERIENCIA EN MECÁNICA O NO ESTÁ FAMILIARIZADO CON LOS PROCEDIMIENTOS DE INSTALACIÓN, HAGA INSTALAR EL PRODUCTO POR UN PROFESIONAL EN UN GARAGE CONOCIDO O EN UN TALLER DE CARROCERÍA.

# 1 Coloque el FrontLoader sobre las barras transversales.

## Abra la mordaza delantera.

Gire la perilla frontal en sentido antihorario para abrir la mordaza delantera.

## Abra la mordaza trasera.

Es posible que deba girar el tornillo en T para permitir que pase a través de la ranura de la mordaza.

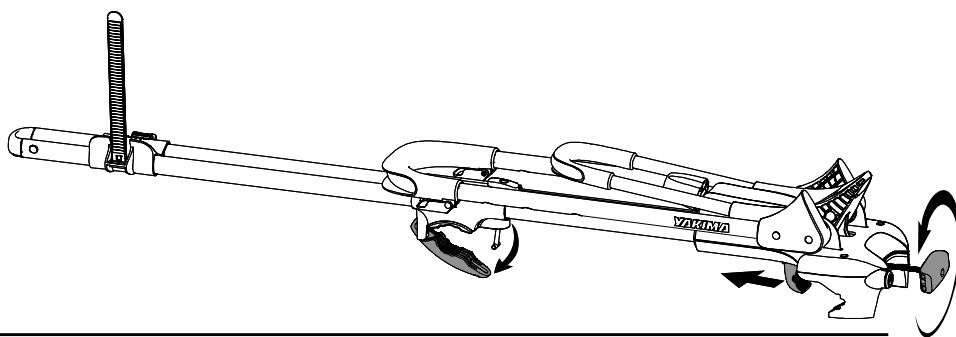

Baje la mordaza delantera hasta que abrace la barra transversal de adelante.

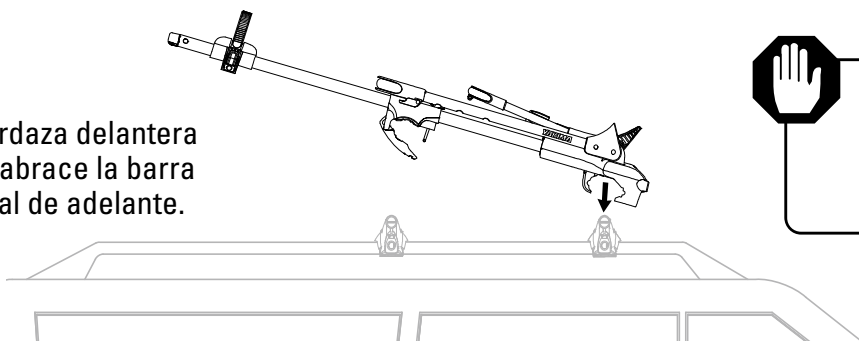

Tenga cuidado de no dañar el acabado del techo. Coloque un paño sobre el techo antes de realizar la instalación para evitar rayarlo.

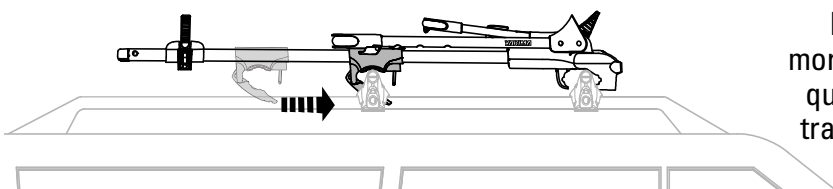

Haga deslizar la mordaza trasera hasta que abrace la barra transversal de atrás.

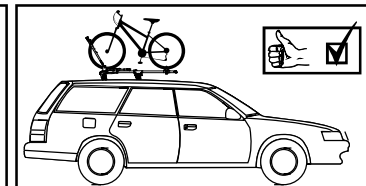
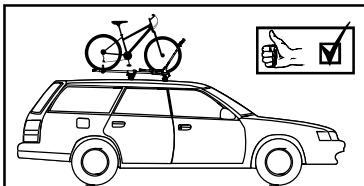
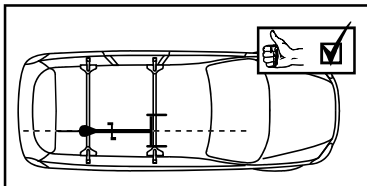
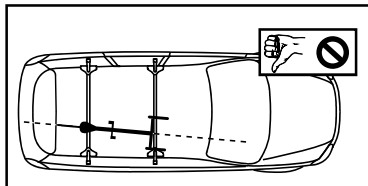
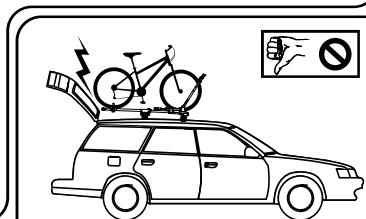

# 2 Apriete las mordazas.

## Apriete la mordaza delantera.

Gire la perilla en sentido horario hasta que la mordaza delantera quede fijada firmemente alrededor de la barra transversal.

## Apriete la mordaza trasera.

Cierre la mordaza trasera alrededor de la barra transversal posterior.

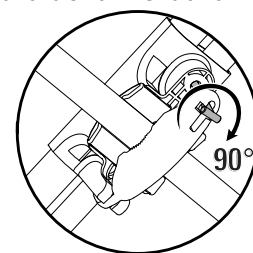
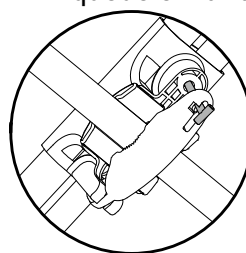
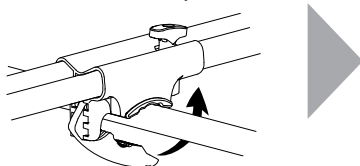

Pase el tornillo en T por la abertura de la mordaza. Gire el tornillo en T para que quede en la ranura de la mordaza.

Gire la perilla en sentido horario hasta que la mordaza trasera quede totalmente apretada.

## Ajuste las mordazas si es necesario.

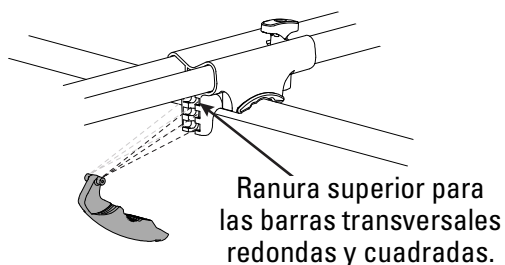

Ranura superior para las barras transversales redondas y cuadradas.



Si no logra un agarre seguro con sus travesaños de origen, ajuste la mordaza.

Para los travesaños de origen, elija la mejor posición que garantice un agarre más seguro.

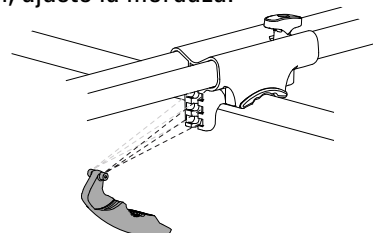



La abrazadera trasera está configurada para las instalaciones típicas. En ciertos casos, puede ser necesario un ajuste, como cuando la rueda toca la perilla trasera o cuando el soporte de rueda no llega a la rueda.

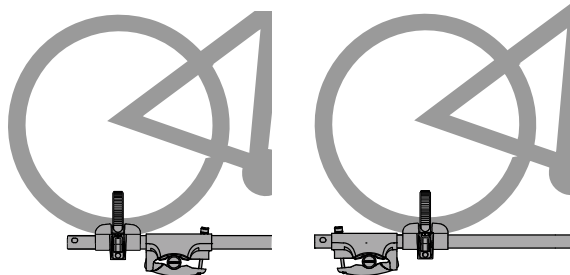

**OPCIÓN A**

Rueda detrás del travesaño trasero.

**OPCIÓN B**

Rueda delante del travesaño trasero.

Si cambiando la orientación de la abrazadera, la rueda trasera aún sigue tocando la perilla, por favor póngase en contacto con nuestro equipo de servicio al cliente (888-925-4621) para recibir gratuitamente un adaptador.

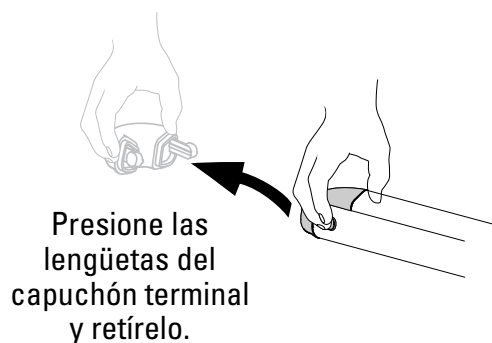
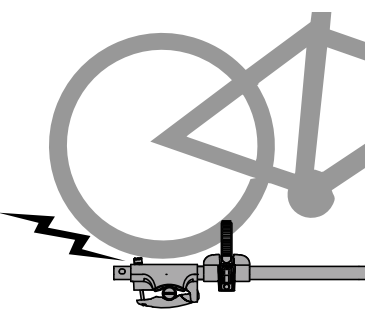

Presione las lengüetas del capuchón terminal y retírelo.

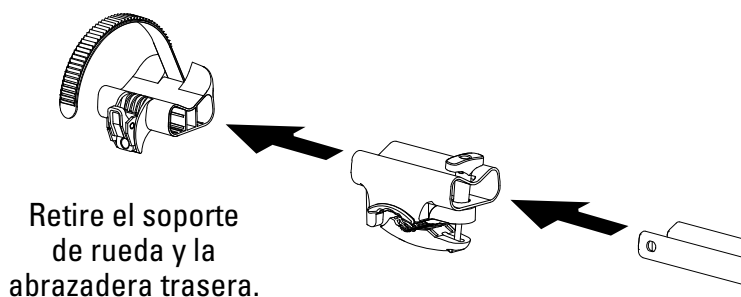

Retire el soporte de rueda y la abrazadera trasera.

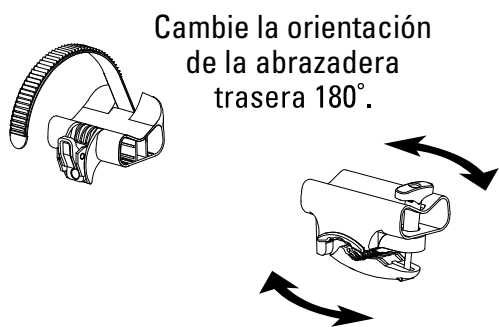

Cambie la orientación de la abrazadera trasera 180°.

NOTA: En caso que sea necesario, es posible retirar el soporte de rueda o la abrazadera trasera en forma independiente. Por ejemplo, si se necesita que la hebilla quede del lado opuesto, es posible rotar el soporte de rueda, tal como se muestra.

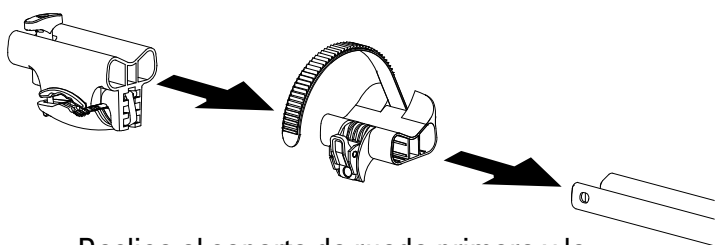
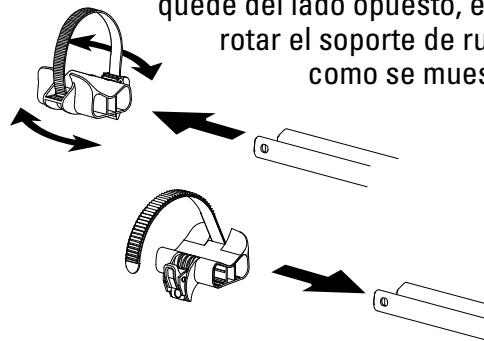

Deslice el soporte de rueda primero y la abrazadera trasera después en el FrontLoader.



Vuelva a instalar el capuchón terminal.

### 3 Ajuste la rueda.

Deslice el sujetador de rueda hasta que el número coincida con la medida del neumático visible a través de la abertura.

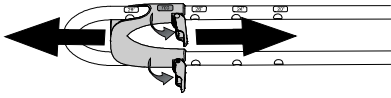

Busque la medida de la rueda de su bicicleta que aparece en el neumático. Abra las palancas rojas del sujetador de rueda para ajustar la altura de sujeción.

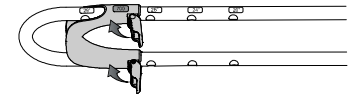
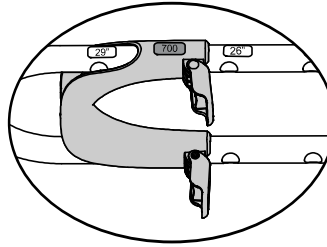

**CIERRE LAS PALANCAS ROJAS.**



Asegúrese de confirmar el perfil de la rueda de la bicicleta para el tamaño de su rueda. Los ajustes para ruedas de tamaño más grande tienen marcas tanto para rangos de tamaño de rueda de bicicleta de pista como de montaña. Siempre utilice el ajuste de rango de tamaño que corresponde con el tamaño de su rueda.

### 4 Cargue la bicicleta.



Abra el portarrueda.

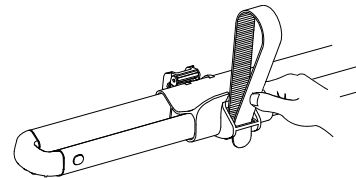

Inserte la correa de rueda en la ranura para facilitar el posicionamiento del neumático.

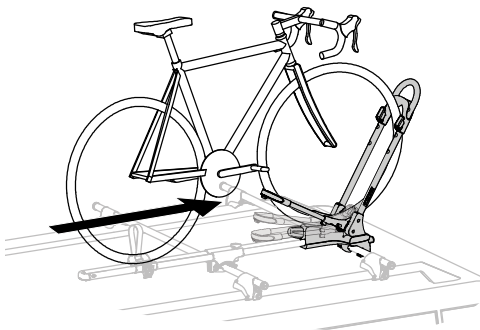

Suba la bicicleta, alinee la rueda delantera con el portarrueda y empújela hacia adelante. El portarrueda pequeño se levantará solo.

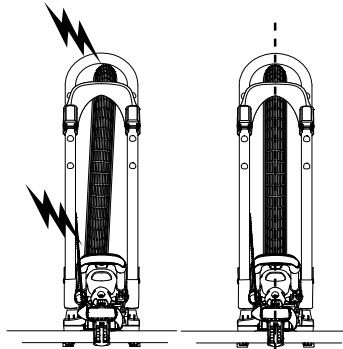

**CENTRE EL NEUMÁTICO EN EL AGARRE DE RUEDA.**

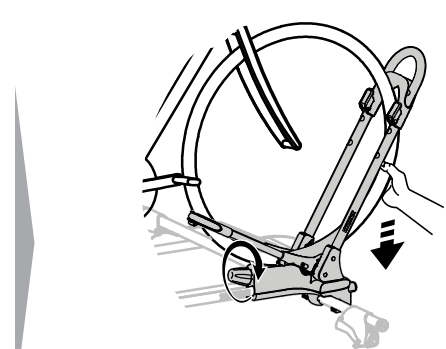

Tire hacia abajo de la rueda mientras que gira la perilla en sentido horario para apretar el portarrueda.



**No emplear este producto si la bicicleta tiene una aleta que impide que los portarruedas hacen contacto directo con el neumático.**

### 5 Asegure la rueda trasera.

- Pase la correa a través de los rayos e insértela en la ranura del soporte de rueda.
- Evite que la correa empuje la válvula.

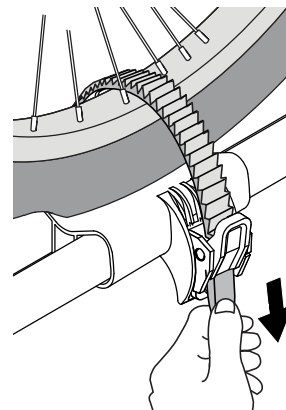
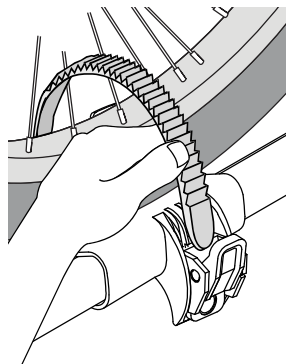

- Tire con fuerza para que quede bien apretada.



## 6 Trabe la bicicleta.



### INSTALE LAS CERRADURAS LOCK CORE OPCIONALES (vendidas por separado).

Si ha comprado una cerradura Lock Core, siga las instrucciones que vienen con la misma para instalarla. Para comprar esas cerraduras (pieza número 8007202 de Yakima) (2 por paquete), visite [www.yakima.com](http://www.yakima.com) o contacte un distribuidor local de Yakima.

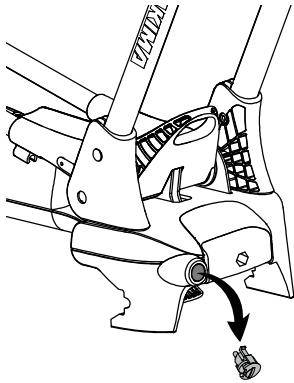

Siga las instrucciones que vienen con las cerraduras Lock Core para retirar el tambor e instalar el de su cerradura.

NOTA: La perilla delantera debe estar en posición horizontal para trabar la cerradura.

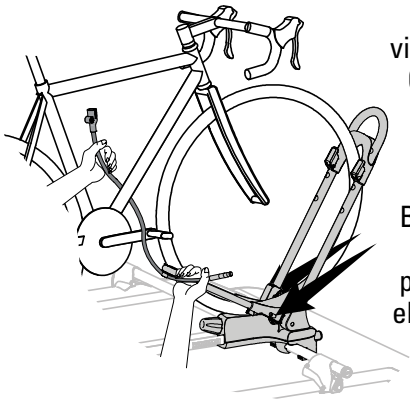
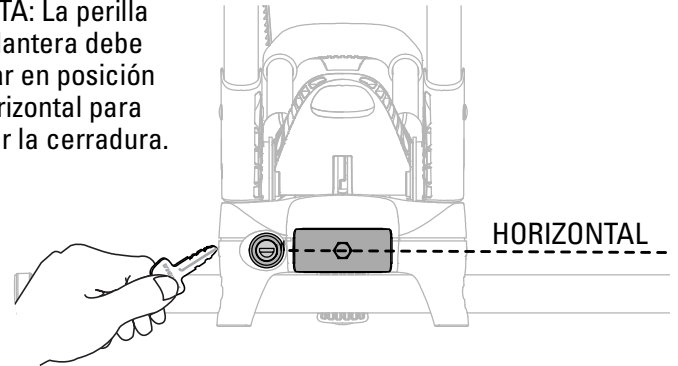

Siga las instrucciones que vienen con las cerraduras Lock Core para retirar el tambor e instalar el de su cerradura.

Busque el cable de seguridad que está incorporado al portarrueda pequeño. Guarde el cable aquí cuando no lo use.

Pase el cable a través del cuadro de la bicicleta e inserte la clavija plateada en el portaclavija de la cerradura.

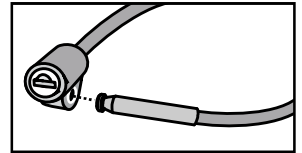

Gire la llave en sentido antihorario para bloquear.

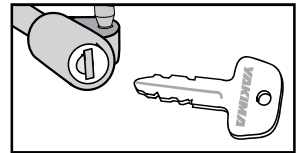

NOTA: Para las bicicletas que tienen un ángulo del tubo de dirección pequeño, una horquilla con suspensión de largo recorrido y una relación tamaño del cuadro/distancia entre ejes muy grande, es posible que el cable de cierre del portabicicleta FrontLoader no alcance a dar toda la vuelta alrededor del tubo inferior del cuadro. Para la mayoría de las bicicletas, esto NO es un problema. Si el cable no alcanza, entonces ajuste el sujetador de la rueda delantera para una de 29".

## ✓ ANTES DE PARTIR

### • VERIFIQUE LA RUEDA TRASERA.

Ajuste la correa si es necesario.

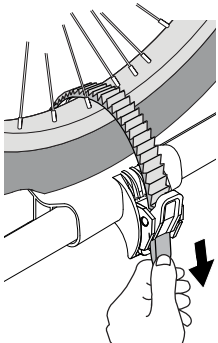

### • VERIFIQUE PERIÓDICAMENTE QUE LAS PERILLAS ESTÁN APRETADAS ADECUADAMENTE.

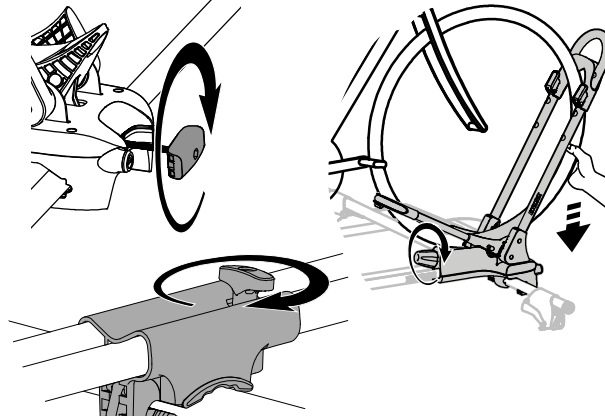

### • VERIFIQUE QUE LA RUEDA DELANTERA ESTÁ BIEN ASEGURADA.

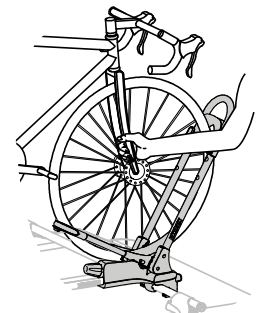

Continúa en la página siguiente...

... antes de partir.

**VERIFIQUE QUE LA RUEDA DELANTERA ESTÁ BIEN FIJADA AL CUADRO DE LA BICICLETA.**

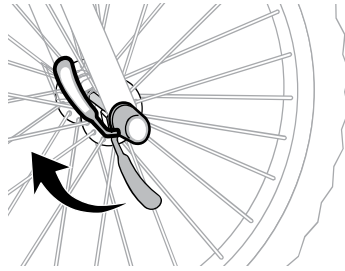

**ASEGÚRESE DE QUE LOS NEUMÁTICOS ESTÁN INFLADOS CON LA PRESIÓN INDICADA EN LOS MISMOS.**

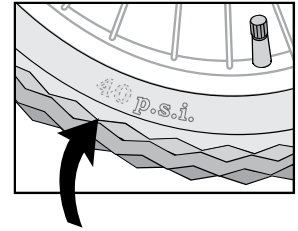

**¡Asegúrese de leer toda la información sobre precauciones y garantías que acompañan estas instrucciones!**



**SI QUITA EL PORTABICICLETA, SIGA LAS INSTRUCCIONES PARA VOLVER A INSTALARLO.**

**Respete las consignas de seguridad después de cada instalación.**



**ATENCIÓN: CERCÍORSE DE QUE TODO EL EQUIPO ESTÁ ASEGURADO SEGÚN LAS INSTRUCCIONES. LAS PIEZAS DE MONTAJE PUEDEN AFLOJARSE CON EL TIEMPO. VERIFIQUE ANTES DE CADA USO Y AJUSTE SI ES NECESARIO.**

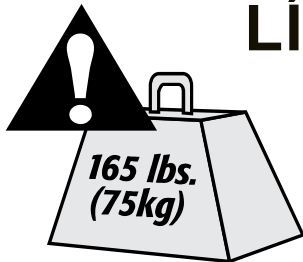

## LÍMITES DEL PESO

Respete la lista de compatibilidad de Yakima, o visite el sitio [Yakima.com](http://Yakima.com) para conocer el límite de peso de su portaequipaje. No exceda el límite de peso de los portaequipajes para su vehículo.

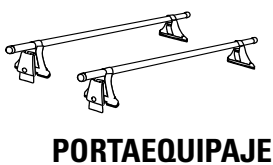

**PORTAEQUIPAJE**

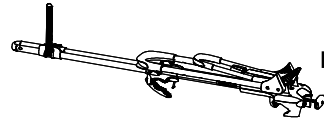

**ESTE PRODUCTO  
(13 lb/5,9 kg)**



**CARGA  
(40 lb/18 kg máximo)**



**No más de 165 lb (75 kg), a menos que se indique lo contrario.**

**\*(Ciertos vehículos están clasificados para menos de 165 lb (75 kg)).**

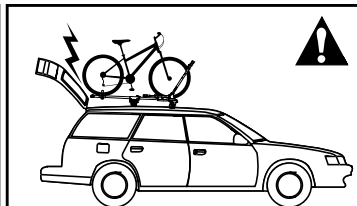
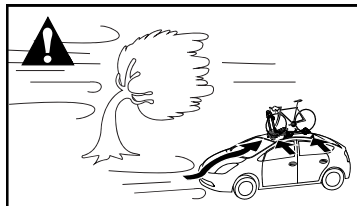
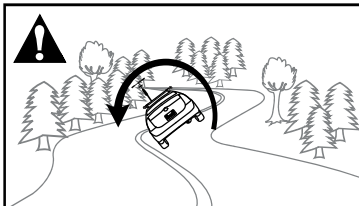
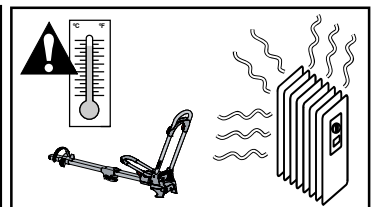
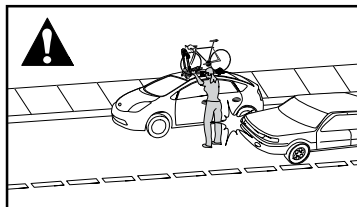
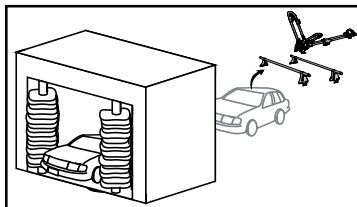
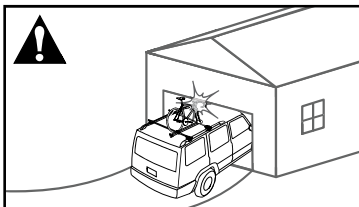

**¡CONSERVE ESTAS INSTRUCCIONES!**